



compatico



CMW System

Installation Manual

Table of Contents

Introduction	2
Tools Required	3
Electrical Power Distribution & Wire Management	4
Pre-Installation Requirements	4
Installation Preparation	4
Installation Sequence	5
Panel Support	5
Load Capacities	6
Panel Installation	7
Connecting Panels to Connectors	7
Connecting Panels to Panels	8
Panel End Cap Kit	8
Panel Height Change—At Connector	9
Panel Height Change—In-line	10
Variable Height Filler Trim	11
Wall Hanger Strips	11
T-Connection Installation	13
Power Distribution	
Specifications & Installation	14
Duplex Receptacles	15
Power Entry	15
Wiring Guide	15
Panel Base & Connector Base Covers	16
Base End Caps	17
Work Surfaces	
Straight	18
Corner	19
Peninsula	21
Transaction Surface	22
Pencil Drawer	22
Overhead Storage	
Shelf	23
Flipper Door	24
Tack Board/Marker Board	24
Task Light	25
Storage Pedestals	25

Introduction

These instructions provide the necessary information to safely install Compatico's CMW furniture system. CMW is a time-tested office partition furniture system that includes a comprehensive vocabulary of panels, power/cabling management, work and storage components as well as accessories.

The characteristics of the CMW system requires panel arrangements and panel supports as outlined in this manual for a safe and secure installation. Rearrangements and additions to an installation must be made to the same stability and installation guidelines to ensure continued safe use. Compatico shall not be liable for product that is used or altered in any other way.

WARNING: Failure to follow these instructions can result in personal injury, product damage and/or property damage.

Tools Required

Many products are shipped assembled at the factory and need only to be installed. Some products are shipped in subassemblies requiring field assembly during installation. The following are tools necessary to properly install Compatico CMW products.

- 12v – 18v Drill/Driver (with spare batteries and charger)
- 3/16" Allen bit for power driver
- #2 and #3 Philips Screwdriver/bits
- 25' – 30' Tape Measure
- Plastic/Rubber Mallet
- Slotted Screwdriver
- 9"-long or longer Magnetic 'Torpedo' Level
- Utility Razor Knife

The following tools will speed-up larger installations or be handy in special circumstances.

- Set of Drill Bits & Screw Bits
- Chalk Line and/or 2" Masking Tape (to locate/mark panel run starts)
- 4' Carpenter's Bubble Level
- Hack Saw or Power Reciprocating Saw with Metal Blades
- Hammer
- Pliers
- 250-lb capacity Wonder™ Bar (pry bar)
- Aviator/Tin Snips (yellow handle)
- Continuity/Electrical Tester
- Panel Skates (for 10 work stations or more)
- Dollies & Panel Carts (for 10 work stations or more)
- Laser Leveler Device (for 10 work stations or more)

Electrical Power Distribution and Wire Management

Electrical power distribution components are modular and allow complete integration with the CMW-series furniture system products. Please read and follow this information carefully before proceeding with any furniture installation requiring electrical components.

WARNING: Disconnect power before servicing any component. Failure to do so can cause electrical shock and personal injury or property damage.

Electrical power system is:

- UL-Listed/CSA-Certified and labeled
- Constructed with shielded conduit to provide an effective built-in EMF barrier
- Eight-wire, four-circuit design
- 15-amp capacity
- Three general-purpose circuits
- One dedicated circuit with isolated ground

Pre-Installation Requirements

The electrical power distribution system is an eight-wire/four-circuit modular system that can supply up to four circuits with single-phase or three-phase power. Each circuit is rated 125v/15-amps and can supply a maximum of 13 receptacles.

1. Before starting the electrical component installation, be sure to coordinate the layout with the building power supply sources.
2. Connection of the electrical components to the building electrical supply *must* be performed by a qualified electrician.

Installation Preparation

Take care examining contents of each box making sure small packages within boxes are not overlooked.

1. Sort and stage all items:
 - Panels
 - Wire Management Connectors
 - Power Components
 - Wall Tracks
 - Cable Poles
 - Work Surfaces and Support Components
 - Overhead and File Pedestal Storage Components
 - Pencil Drawers and Accessories
2. Review building drawings closely to determine exact location of panel runs.
3. Mark floors with chalk lines and/or tape to mark starting points and openings.
4. Start at high point of the floor, if possible.

Installation Sequence

Compatico recommends the following sequence to assemble CMW product:

1. Install Panels.
2. Install Power Distribution and In-feeds (not wired to power supply).
3. Install Overhead Storage and Task Lights.
4. Install Work Surfaces and Floor-supported/hanging Pedestals and/or File Centers.
5. Install Tack Boards.
6. Install Accessories.
7. Test flipper doors and file drawers for smooth function and proper alignment.
8. Wipe down furniture.

Panel Support

These panel installation instructions are written for user safety. Please follow them at time of planning and specification, initial installation and any addition or reconfiguration.

Definition and Application:

1. Panel runs are any two or more panels connected in a straight line.
2. Panels mounted at right angles to panel runs are called support panels. Height of support panels must be equal to the height of the panels in a run or
 - 65”h for 80”h panels
 - 53”h for 65”h panels
 - 41”h for 53”h panels
3. All support panels must be at right angles to run panels and on one or both sides of run panels, depending on the panel loading, and spaced no more than ten feet apart.
 - Panel runs loaded on one side with overhead storage and/or work surfaces must have support panels on the loaded side with 36” minimum width at the beginning and ending panels and at intervals not to exceed ten feet; for Acoustical, Glazed and Open-Frame panels, must not exceed eight feet.

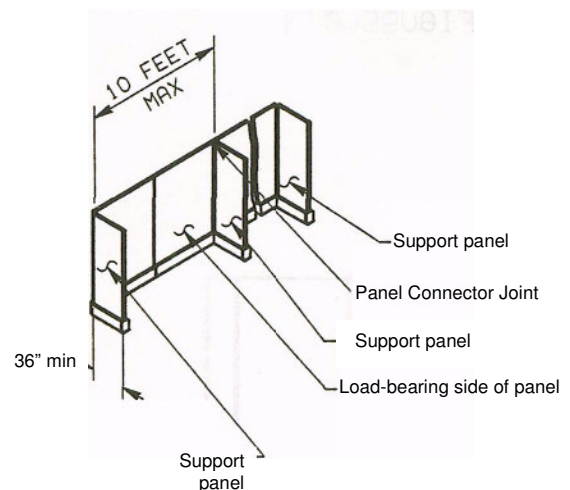

- Panel runs loaded on both sides with overhead storage and/or work surfaces must have support panels on both sides of the run. Support panel width must correspond to the depth of the deepest component mounted to the panel run on that side of the run at the beginning and ending panels and at intervals not to exceed ten feet; for Acoustical, Glazed and Open-Frame panels, must not exceed eight feet.

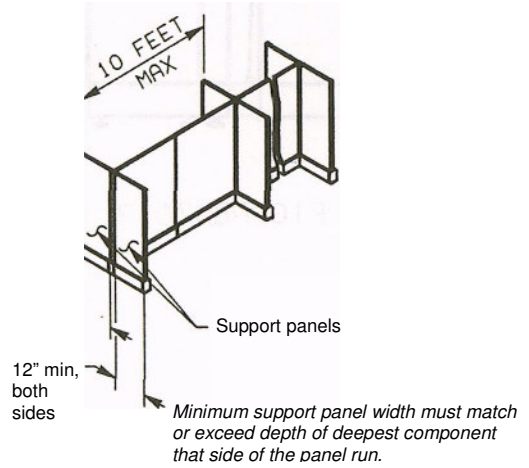

4. Panel-to-Wall bracket kits are used to connect panel runs to a structural wall or building column.

- A structural wall is a load-bearing wall constructed of poured concrete, cement blocks or composite board attached to metal or wood studs.
- Wood studs must be a nominal 2" x 4" size.
- Metal studs must be 20-ga. "c"-channel, center-to-center dimension not to exceed 24" and be less than 14' tall, restrained at both ceiling and floor.

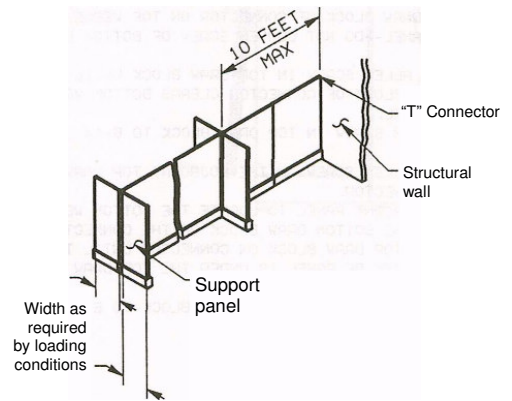

Panel Creep

Small increments are added to the length of a run of panels because of the different ways that panels are connected to each other. The accumulation of these increments is called panel creep—see example below.

- Add $1 \frac{11}{16}$ " each time a perpendicular panel is inserted into a run of panels with universal connectors.
- Add $1 \frac{27}{32}$ " each time a perpendicular panel is joined to the end of a panel run with a universal connector.
- Add $\frac{1}{32}$ " for each straight connection between panels in a run.
- Panel width is $\frac{5}{16}$ " greater than nominal dimension, e.g. $30 \frac{5}{16}$ "

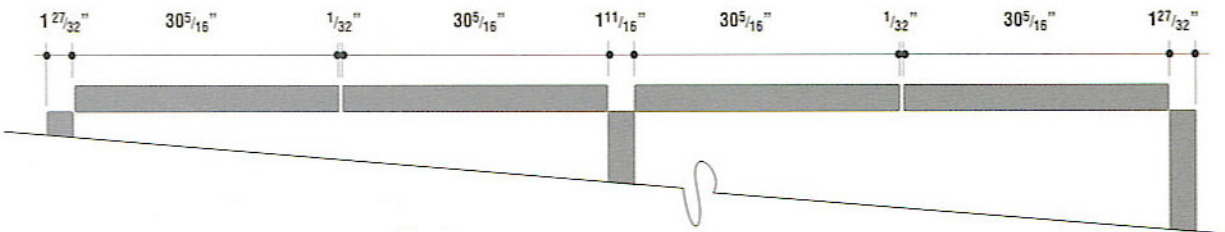

$$4 (30 \frac{5}{16}) + 2 (\frac{1}{32}) + 2 (1 \frac{27}{32}) + 2 (1 \frac{27}{32}) = 125 \frac{25}{32}$$

Load Capacities

Compatico will not, under any circumstances, guarantee or assume responsibility for loading performance beyond the basic individual component capacities given below:

- Hanging work surfaces, 60" or less wide:
 - 250 lbs, 18" deep
 - 200 lbs, 24" deep
 - 200 lbs, 30" deep
- Hanging work surfaces, 66" – 96" wide:
 - 250 lbs, 24" deep (with three work surface supports)
 - 250 lbs, 30" deep (with four work surface supports)
- Shelves: 150 lbs
- Hanging storage pedestal (Box/File): 25 lbs
- Pencil drawers: 5 lbs

Load capacities as listed above for work surfaces include the total load of fully loaded hanging components attached to the underside of the work surface plus the load placed on the top of the work surface.

WARNING: *Failure to observe the recommended practices such as loading beyond stated capacities can result in unsafe usage conditions and product damage or personal injury or both.*

Before storage components and accessories are installed on panels, be sure to level panels and adjust each panel glide to make firm contact with the floor to maintain panel alignment and to distribute panel load uniformly to floor. Check panel stability after installation is complete and furniture components are attached; adjust any panel glides as may be necessary.

Panel Installation

Important:

- *Start at a 2-way, 3-way or 4-way connector junction so that the initial panels, once connected, will remain free-standing; then build from there according to your layout print. Construct this connector junction at a locatable point from the layout print on the installation floor. Use chalk line or masking tape to mark the starting location.*
- *Each panel includes one Universal Connector package, shown at right, to connect panels of the same height in straight, L-, T- or X-configurations.*

Universal Connector package includes:

- (2) Top/Bottom connector plates
- Tear-drop filler
- End filler
- (2) pins
- (6) 3/16" Allen screws

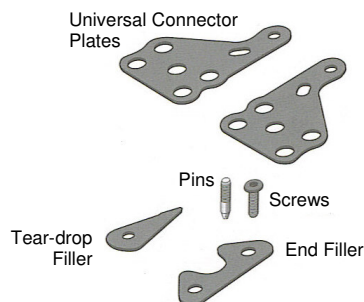

- *Connecting panels of varying heights requires Varying Height hardware kits, ordered separately.*
- *Be sure to level panels before installing components.*

Connecting Panels—Same Height

1. Follow the diagrams below to make the standard connections between panels of same height. The universal connector plates are used and oriented in the same manner shown at both the top and the bottom of the panels.

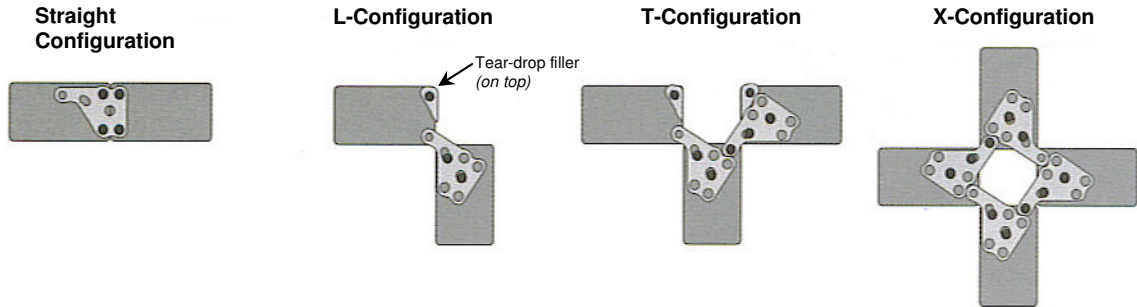

2. Before placing a panel into position, attach the appropriate hardware to each bottom end of the panel: pin(s) at one end and a connector plate at the other; the positioning of the bottom connector plate mimics the positioning of top connector plate, prepared for the position of the next panel.

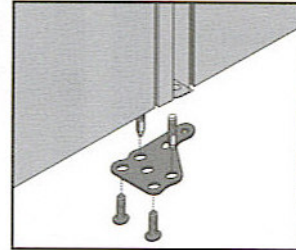

3. As each subsequent panel is positioned, first place the pin(s) into the bottom connector plate of the previous panel, then draw the panels together at the top and join with a connector plate as shown at right (*straight connection*).

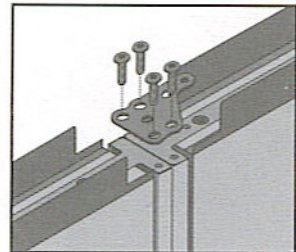

4. At each L-, T- or X-connection join the panels with universal connectors as shown with 3/16" Allen screws. Fill each reveal line gap with a Tear-drop filler and 3/16" Allen screw(s).

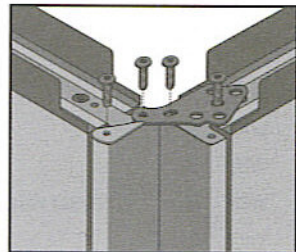

5. Panels at the end of a run do not need a bottom connector plate. At the top, attach an End Filler with two 3/16" Allen screws.

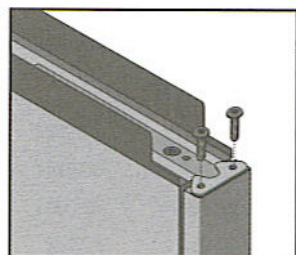

Connecting Panels—Varying Heights

Connecting panels of varying height requires optional connector packages, specified separately. Where two or more panels of the same height join as well, use the standard Universal Connector kit described in the section above.

- At right are the two optional connector kits, *Straight* and *Angle* for accomplishing varying height panel connections.
- Brackets are specified as pairs and based on the height of the lower panel to be attached to a taller panel.
- If you plan to attach overhead storage components while using either of these connector kits, make sure there is enough height above the connector to attach the overhead to the panel's slotted channel (connector occupies two slots of the slotted channel).

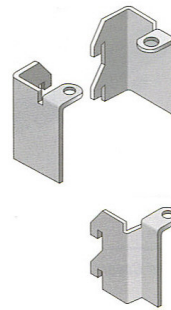

'Straight' varying-height connector package
(Right-hand bracket shown on left)

'Angle' varying-height connector package
(Right-hand bracket shown on left)

1. Follow the diagrams and notes below to determine the appropriate type and size varying height connector package to use.

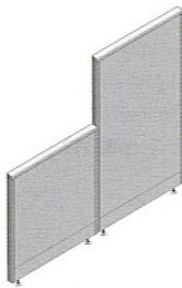

Use "Straight" brackets (one pair)—Use brackets for lowest height panel

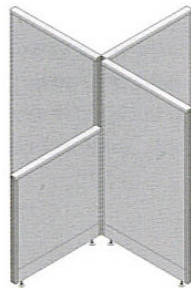

Use "Angle" brackets (one pair)—Use brackets for lowest height panel

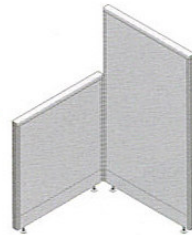

Use "Angle" bracket (right hand) — Use bracket for lowest height panel

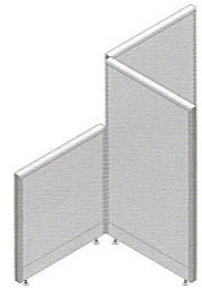

Use "Angle" bracket (right hand) — Use bracket for lowest height panel

2. Before placing a panel into position, attach the appropriate hardware to each bottom end of the panel: pin(s) at one end and a connector plate at the other; the positioning of the bottom connector plate mimics the positioning of top connector plate on the panels at a connection which are the same height.
3. As each panel at the connection is positioned, first place the pin(s) into the bottom connector plate of the panel at the connection, then draw the panels together at the top of the lower panel and secure the lower panel to the taller panel with the varying height connector and 3/16" screw(s).
4. At each L-, T- or X-connection, fill each exposed reveal line gap with a Tear-drop filler and 3/16" Allen screw.

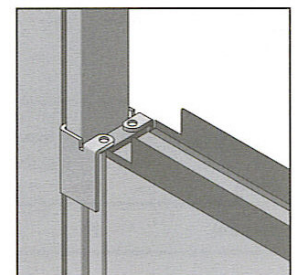
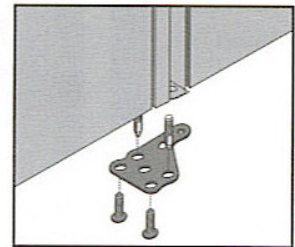

'Straight' connection detail shown.

Wall Hanger Strips

Note: Wall hanger strips must be used only on a structural wall constructed in either of the following manner, as a minimum:

- *Composite Board (drywall) over Wood or Metal Stud: Drywall must be 5/8" minimum, on 2" x 4" studs minimum, 24" on-center maximum; 14' height maximum, retained at both floor and ceiling. Metal studs must be "C"-channel, 20-ga minimum thickness. Drywall must be attached by industry standards, minimum; ideally it should include appropriate adhesive bead on each stud, the full length of the stud.*
- *Poured cement wall*
- *Cement block wall*

Acceptable fastener recommendations:

- *Into drywall on studs:*
 - *3/16" hollow wall fastener or 3/16" wall toggle & bolt with #8 flat head machine screw located 29" and 60" from floor, minimum; other screw locations can utilize 1/8" fastener/wall toggle with #8 flat head machine screw.*
 - *Directly into wood stud: #8 x 2 1/2" flat head drywall or sheet metal screw.*
 - *Directly into metal stud: #8 x 2 1/2" flat head sheet metal screw.*
- *Into concrete, cement block or brick:*
 - *#8 x 1 1/2" flat head sheet metal screw with screw anchor.*
 - *3/16" x 1 3/4" Tapcon™ or other brand concrete anchor screw. Must be used with recommended (5/32") masonry drill bit for pilot hole.*

Note: Refer to fastener manufacturer's specifications and recommendations for application, load rating and pilot hole size. It is the installer's responsibility to determine and select the most appropriate fastener. Compatico does not assume any liability for their use.

Warning! *Failure to properly attach wall hanger strips to a structural wall and, where possible, to rest wall hanger strips directly on the floor may cause dislodgement of wall strip and/or attached components causing personal injury and/or property damage.*

Location and installation:

Note: Wall hanger strip must be secured to wall with appropriate fastener every 6".

1. Position the first wall hanger strip at the required location, per furniture layout drawing. Note that the end with the hole located closest to the end is the top. Attach at top with fastener.
2. Use a level to 'plumb' wall hanger strip; mark hole locations on wall through holes in wall hanger strip.
3. Drill holes, at each marking, in wall according to fastener manufacturer's recommendation.
4. Insert fastener and complete attachment of wall hanger strip.
5. Measure or use a spacer to locate and mark the next wall hanger strip location.
6. Repeat steps 2 –5 for remainder of wall hanger strips.

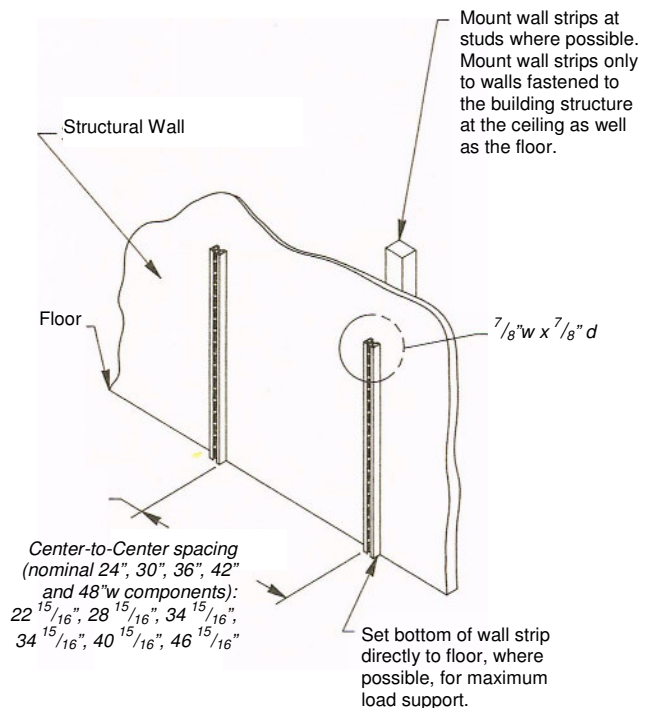

Helpful Hints:

- *Spacers may be used to position subsequent, sequential wall strips. Cut spacers to 7/8" less than nominal component dimension +/- 1/32". Be sure to keep ends cut square.*
- *Installers are responsible to install wall strips at a uniform height and level relative to one another. Often, if a drop ceiling is present, their perimeter track has been installed with a laser level. Because floor levels vary, especially cement floors, the ceiling tile track may be a better reference for locating wall strip's vertical position. Installer must determine best method for keeping wall strips level because their location is critical to the subsequent outcome of the furniture installation.*

Panel-to-Wall Connection Installation

Use to connect a panel at a right angle to a structural wall..

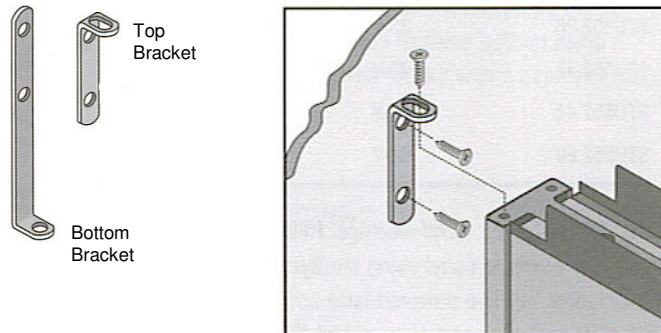

Notice: It is the installer's responsibility to select and install the proper fasteners in the structural wall; Compatico does not assume liability for their use.

Note: Structural wall should be constructed in either of the following manners, as a minimum:

- Composite Board (drywall) over Wood or Metal Stud: Drywall must be 5/8" minimum, on 2" x 4" studs minimum, 24" on-center maximum; 14' height maximum, retained at both floor and ceiling. Metal studs must be "C"-channel, 20-ga minimum thickness. Drywall must be attached by industry standards, minimum; ideally it should include appropriate adhesive bead on each stud, the full length of the stud.
- Poured cement wall
- Cement block wall

For attachment to structural wall:

1. Select appropriate fastener for type of structural wall and mount the top and bottom brackets to accommodate the height of the panel to be attached. If wall is very out of plumb, consider using a beveled furring strip attached solidly to the wall, then attach the panel-to-wall brackets to it.
2. Attach a pin to the bottom end of the panel; position the pin into the bottom bracket.
3. Secure the top of the panel to the top bracket with a 3/16" Allen screw.

Power Distribution

Compatico eight-wire/four-circuit power system specifications:

- UL-Listed/CSA-Certified and labeled
- Constructed with shielded conduit to provide an effective built-in EMF barrier
- Eight-wire, four-circuit design
- 15-amp capacity
- Three general-purpose circuits
- One dedicated circuit with isolated ground

Compatico CMW series panels specified with power come with the power distribution harness attached to the panel.

To connect power distribution harnesses and/or pass-thru cables together or between one or another

1. The flexible conduit/connector is polarized so that it can only connect to the appropriate end of a pass-thru cable or to the male terminals on the power block of a power distribution harness (one terminal on the male end of the connector is crowned).

If the power distribution harness needs to be removed, remove the power block from mounting bracket, use a small prybar or flat-blade screwdriver to press down plastic tab of power block on either side of the mounting bracket center tab until you can push the power block through.

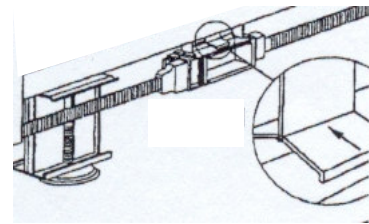

2. Simply make sure the polarized ends are appropriately matched and press together. You should hear an audible 'click' when they have made a proper connection. If not, please examine carefully to make sure the two are fully connected by firmly pulling apart.
 - The shielded cable of each Power Distribution Harness and Pass Thru cable can be stretched up to 3 1/2" to round 90-degree corners; firmly grab shielded cable only at each end and pull sharply until fully stretch.
 - Separate adapters (Compatico #HMP.554.0300) are required only to pass through a 3-way or 4-way connector.
3. Follow the schematic below for routing power distribution harnesses and/or pass-thru cables at connector junctions.

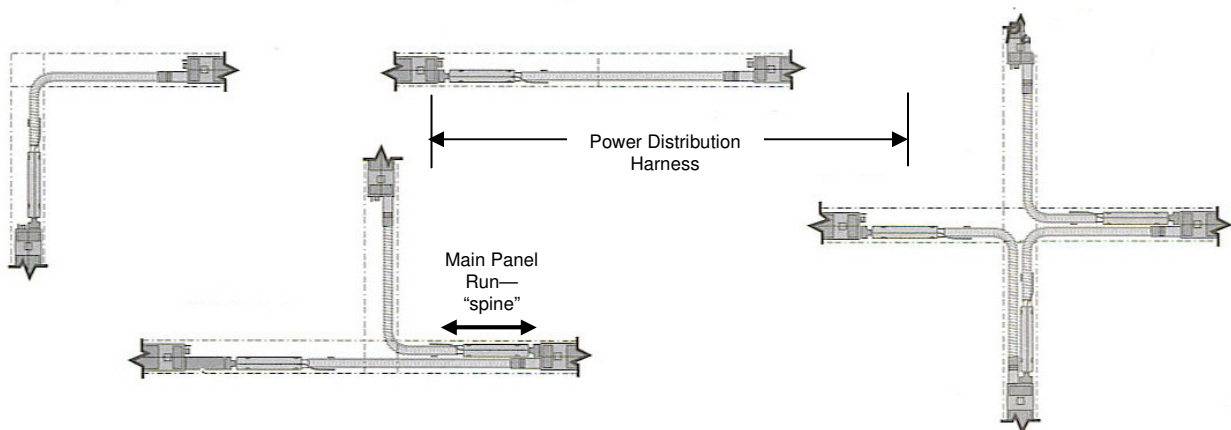

To install Duplex Receptacles

Slide and snap duplex receptacles into each Power Distribution block where indicated according to electrical plan. Knock out appropriate duplex covers on each base cover.

To remove duplex receptacle, press release tab on power block and slide duplex receptacle out.

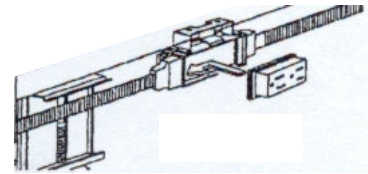

Power Entry

1. Insert end into power distribution harness block and slide into position until you hear an audible 'click'; thread free end through panel base side cover and install base side cover.

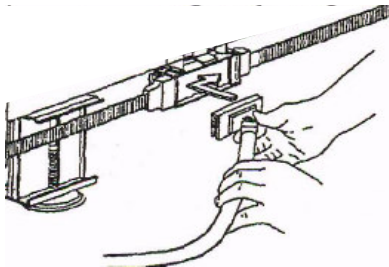

2. Rotate conduit to the right or left and add Power Entry cover, Secure with two screws provided. *Power Entry is now ready for electrician to hardwire the connection to the building supply.*
 - End Feed and Ceiling Feed cables connect to power distribution block male terminals on end of block.

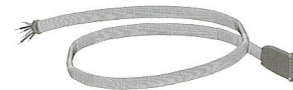

Ceiling Feed

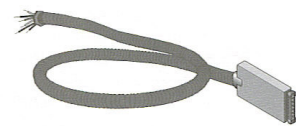

End Feed

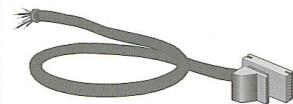

Side Feed

WARNING

- *Risk of Fire or Electrical Shock. Each panel must be connected to only one source of electrical supply. Be sure to turn off panel board switch while installing or removing power entry.*
- *Power Entry must be installed by a licensed electrician.*

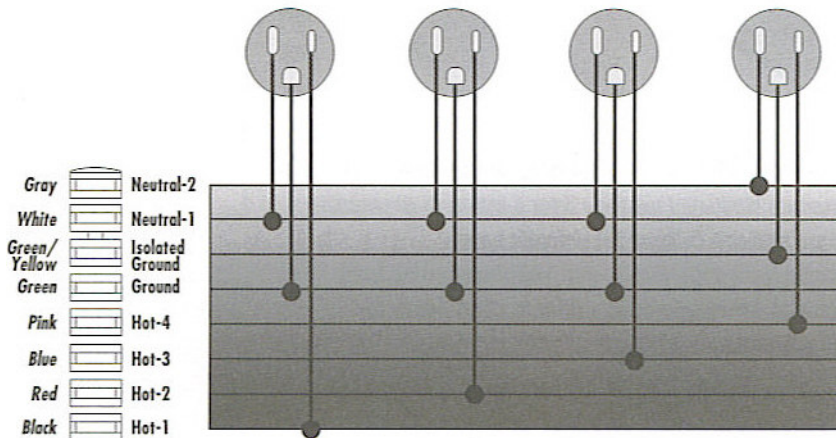

Base & Connector Raceway Management

Opening Panel Base Side Covers:

Side covers are retained by the top channel and pivot at the baseplate.

1. To remove side cover, start at one end and press down on the top edge of the side cover to clear the lip from the top channel; pull toward you as your finger continues pressing down on the top edge as it slides along toward the other end.
2. Rotate side cover down toward you to allow access to the cable management channel.

Closing Panel Base Side covers:

Note: Connector trim covers must be closed before closing side covers.

1. Start at one end of the side cover and press down on the top edge until the lip is under the top channel.
2. While holding that end in position, press and run finger along the top edge seating the rest of the lip under the top channel.

Connector Trim Covers:

- Trim covers are completely installed on all post connectors, except 4-way connectors which have a base post but no trim cover.
- Trim covers pivot at the base and hold their position with a latch that engages the connector.
- To release the trim cover, press down and in with a flat blade screw driver, near the center at top. When the trim cover latch clears the edge of the connector, rotate the trim cover back.

Wire Management End Cap Installation and Removal:

Note: End caps must be installed before closing panel base side covers.

To Install:

1. Insert end cap hooks into the baseplate slots, as shown at right.
2. Rotate the end cap upward until the end cap latch catches the top channel hook. Confirm, by pulling back on the top of the end cap.

To Remove:

1. Use a flat-blade screw driver to pry down on the end cap latch beneath the panel end trim.
2. When the latch clears the top channel hook, pull back on the top of the end cap until the end cap hooks disengage from the baseplate.

Work Surface Installation

- Work surfaces include pilot holes for standard location at each end.
- Work surface spans should not exceed 48" without proper depth support such as cantilever support arm, clear-access support panel, C-leg or dual-tube peninsula support leg. Sagging and warping of work surface will occur without a reinforcing channel attached beneath.
- Load capacities:
 - Up to, and including, 48"w (24"d, 30"d): 200lbs.
 - Less than, and including, 96"w (25"d, 30"d): 250lbs.
- Warning: Load capacities, as listed, include the total load of the work surface, including storage components hanging from the work surface such as pencil drawers and box/file hanging pedestals. Failure to observe the recommend loads and applications will result in unsafe usage conditions which could result in product failure and/or personal injury.
- Work surfaces can be adjusted in 1"-inch increments on either panels or wall tracks. Typical work surface heights are:
 - Machine usage/full-time keying: 25" from floor to top surface
 - Sit-down/Typical desk usage: 28"–30", depending on size of person; 29" most normal
 - Stand-up height: 36"--42"
 - Set top of cantilever at 1" below desired work surface height

To install cantilever support arms:

1. Engage either left-hand or right-hand support arm in the appropriate panel side or wall hanger strip at the desired height. See illustration. The cantilever support arm must rest fully beneath the work surface and flush to the end.

Important note: CMW-style support arms and hanging brackets which attach to panels and wall hanger strips have a built-in anti-dislodgement feature—the bracket ‘teeth’ are curved requiring the bracket to be engaged in the following manner:

- a. Tip the top, back of the bracket into the slotted track of a panel or wall hanger strip so that the top tooth will engage first.
- b. Position the bracket slightly offset to the outside of the components location and, with the top tooth engaged, drop the rest of the bracket against the slotted channel and into position.
- c. **Tap the bracket firmly downward to securely seat the bracket.**

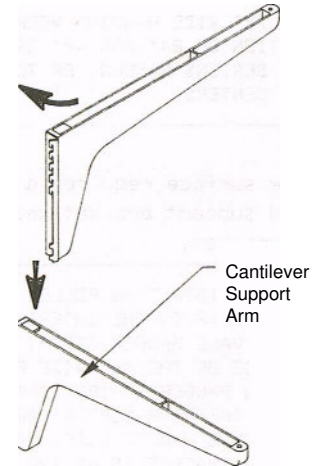

2. In the same manner, engage the opposite side support arm.
3. Install work surface retainer/guides into pre-drilled holes, for standard end-mount. ‘Button’-style screw goes to rear location; ‘pin’-style screw goes in forward location.
4. “Tip” work surface into position, as shown below right, guiding rear of retainer or “button” screw into the slots/keyhole slot of cantilever.

Note: early CMW-style retainers are used with cast-aluminum cantilever support arms; button/pin screws are used with pressed steel cantilevers.

5. Adjust hex screw at front of cantilever to level work surface, front-to-back.

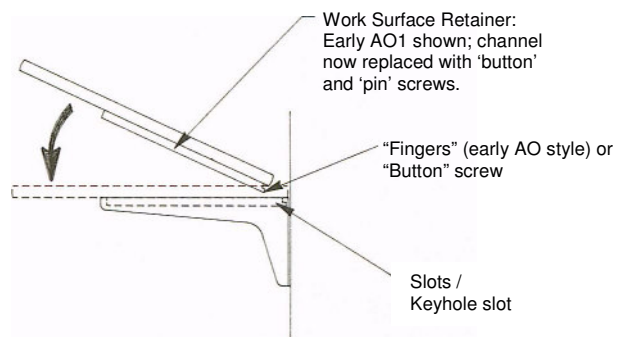

Corner Work Surface Installation

CMW utilizes separate 'button' and 'pin' screws which must be mounted to the work surface. The "pin" is mounted ahead of the "button" and fits into the holes just behind the leveling screw at the top front end of the cantilever support arm.

- Work surfaces include pilot holes for standard location at each end.
- Load capacity: 200lbs. total load of the work surface, including weight of any component attached to the underside such as a keyboard tray.
- Failure to observe the recommend loads and applications will result in unsafe usage conditions which could result in product failure and/or personal injury.
- Work surfaces can be adjusted in 1"-inch increments on either panels or wall tracks. Typical work surface heights are:
 - Machine usage/full-time keying: 25" from floor to top surface
 - Sit-down/Typical desk usage: 28" –30", depending on size of person; 29" most normal
 - Stand-up height: 36"--42"
 - Set top of cantilever at 1" below desired work surface height

To install cantilever support arms and work surface support bracket:

1. Engage either left-hand or right-hand support arm in the appropriate panel side or wall hanger strip at the desired height. See illustration. The cantilever support arm must rest fully beneath the work surface and flush to the end.

Important note: CMW-style support arms and hanging brackets which attach to panels and wall hanger strips have a built-in anti-dislodgement feature—the bracket 'teeth' are curved requiring the bracket to be engaged in the following manner:

- a. Tip the top, back of the bracket into the slotted track of a panel or wall hanger strip so that the top tooth will engage first.
 - b. Position the bracket slightly offset to the outside of the components location and, with the top tooth engaged, drop the rest of the bracket against the slotted channel and into position.
 - c. **Tap the bracket firmly downward to securely seat the bracket.**
2. In the same manner, engage the opposite side support arm.
 3. Insert Work Surface Support Bracket (part number HMP455.02) in either panel slot at the rear corner connector or wall hanger strip, depending on whether the bracket is a 'left' - or 'right' -hand bracket as shown below, right.
 4. Install work surface retainer/guides into pre-drilled holes, for standard end-mount. 'Button'-style screw goes to rear location; 'pin'-style screw goes in forward location.
 5. Install work surface retainer/guides into pre-drilled holes, for standard end-mount. 'Button'-style screw goes to rear location; 'pin'-style screw goes in forward location.

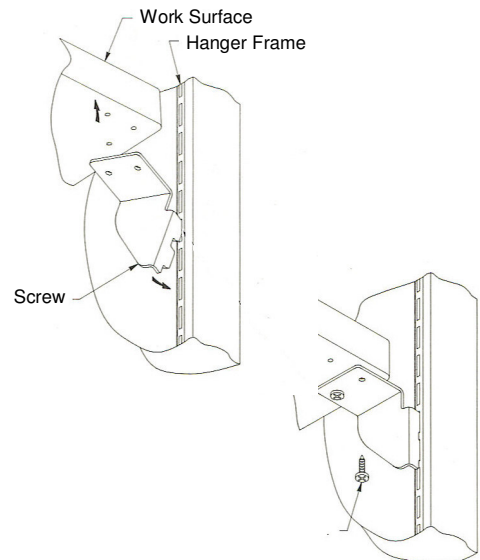

Corner Work Surface Installation--*continued*

6. Position the corner work surface over support hardware as shown below. Engage the retainer or "button" and "pin" screws of one side into the cantilever support arm as shown below, right. On the other side, eliminate the "button" screw, using the "pin" screw to locate it on the support arm.
7. Lower corner work surface fully into position and be sure it is securely seated on all three support brackets.

Note: early CMW-style retainers are used with cast-aluminum cantilever support arms; button/pin screws are used with pressed steel cantilevers.

8. Attach the work surface to the rear corner bracket with two screws; tighten screws securely.
9. Use work surface connecting plates to join corner work surface to adjoining work surfaces.
10. Adjust hex screw at front of cantilever to level work surface, front-to-back.

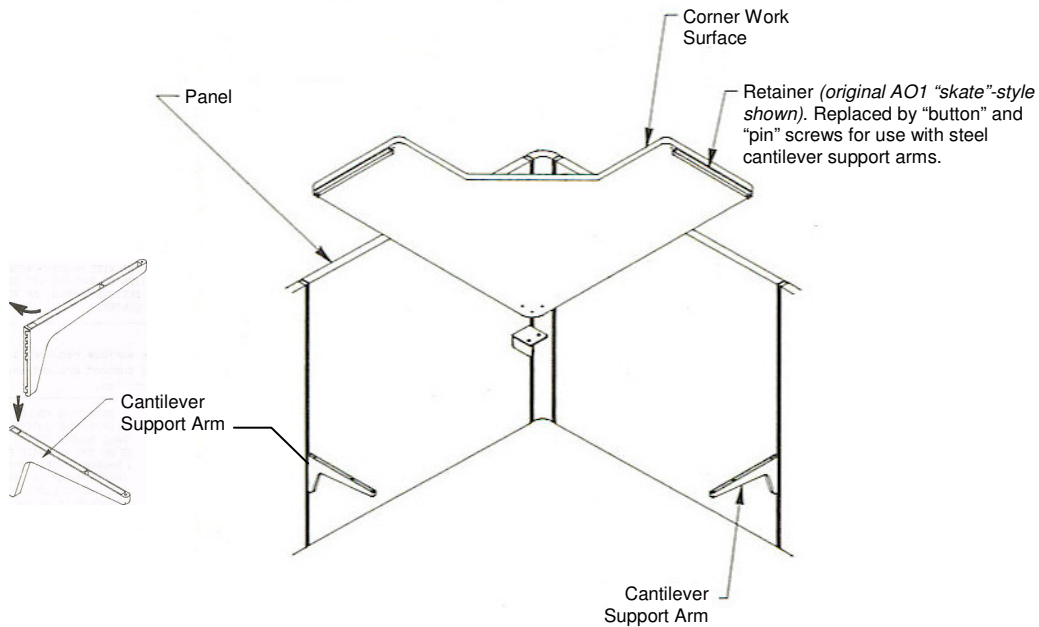

Peninsula Work Surface Installation

Work Surface-supported Installation:

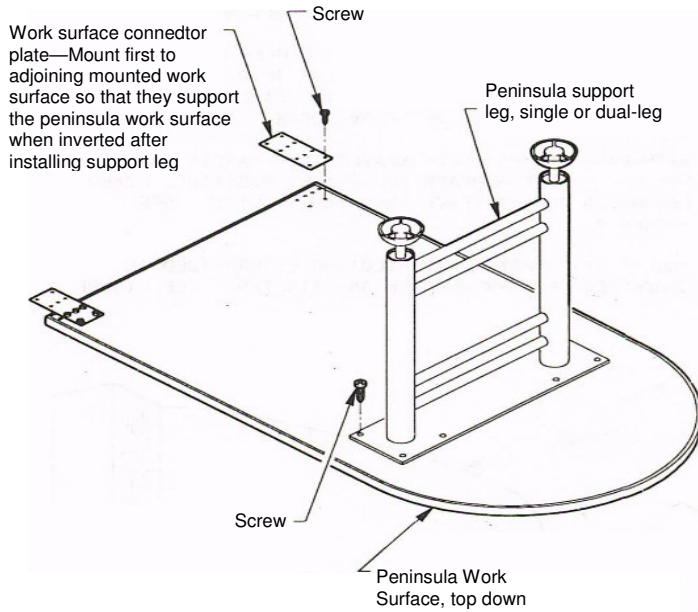

1. Lay work surface, underside up, on a clean, padded surface.
2. Center support leg, whether single or dual-leg, set back from end $\frac{1}{2}$ the depth (radius) of the surface. Secure with screws.
3. Mount two work surface connecting plates to the adjoining, mounted work surface as shown below.
4. Place peninsula work surface over the connecting plates and secure with screws.
5. Adjust glides to level peninsula work surface.

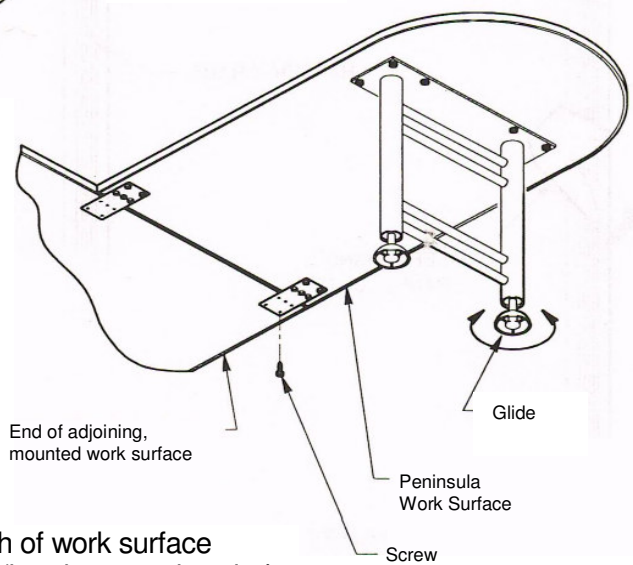

Peninsula Work Surface Installation

Panel-supported Installation:

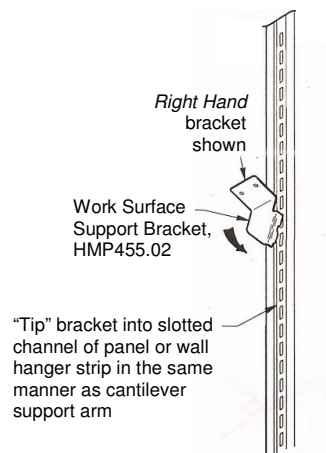

1. Engage top tooth of work surface support bracket (brackets are *handed*) into slotted channel of panel frame or wall hanger strip, as shown at right. Then rotate bottom of bracket down into position of slotted channel. Typical height for installation is approximately 28" from floor to the top of the support bracket.
2. With the panel clips firmly seated, lower the peninsula work surface onto the brackets as shown, below right.
3. Drive two screws into each bracket until tight.

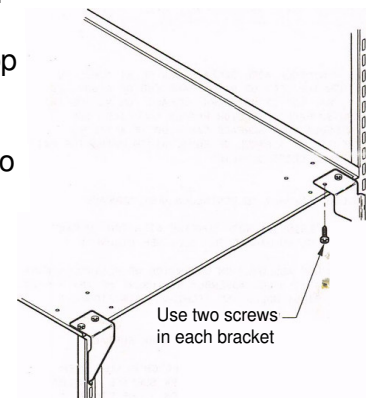

Transaction Surface Installation

1. Turn out allen screw of finished end top block or panel-to-panel connector draw block, depending on application.
2. Remove top block or draw block and replace with appropriate transaction counter bracket. See description of each application at right, below with respective transaction counter support bracket.
3. Install connector or finished end as described in "Panel Installation" above.
4. Position transaction counter over supports and align in both directions. Attach counter to supports with #12-10 x 1 ¼ Flat Head Philips screws.

Pencil Drawer Installation

1. Attach drawer bearers to work surface as shown at right with flat-head wood screws supplied.

Note: Closed-end of drawer bearers face rear of work surface.

2. Use drawer bearer dimensions/spacing shown below wherever pencil drawer is desired.

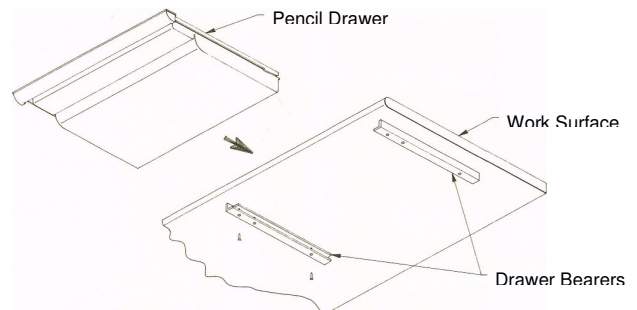

Shelf Installation

Note: All screws must be firmly tightened. Failure to do so may cause the shelf to fall, causing product damage or personal injury.

1. Loosen both bottom shelf mounting screws on each end panel to reveal approximately 1/8" of screw thread. Bottom screws are for the shelf; top screws are for the flipper door assembly or additional shelf, if specified.
2. Engage shelf end panel at desired height in slotted hanger frame of panel or wall track channel as show at right, top.
3. Swing shelf end panel to perpendicular with panel or wall and lock shelf end panel in place by pushing down on end panel to seat the bracket. Tap firmly with plastic mallet to ensure end panel is fully seated on hanger frame or wall hanger strip.
4. Position end panels perpendicular to wall and slide shelf straight in between shelf end panels, just above the mounting screws. Seat shelf pan securely on the mounting screws and tighten with a Philips screw driver; be certain to tighten all screws firmly.

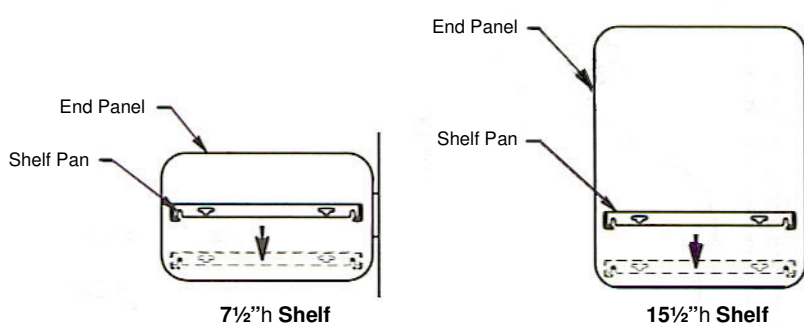
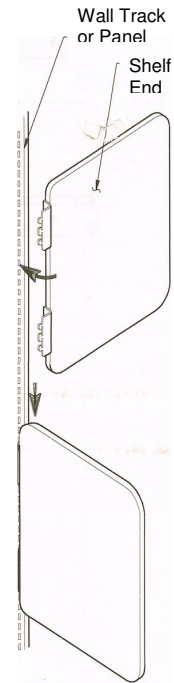

Shelf Divider

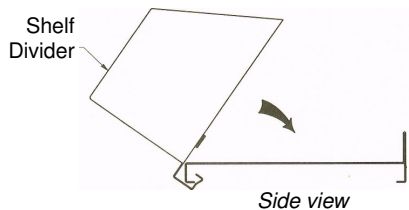

1. Install shelf divider by tilting divider forward and hook under lip of shelf as shown.
2. Pivot divider so that it rests flat on the shelf.

Flipper Door Installation

1. If a flipper door cover is to be installed, first install the shelf unit but do not tighten the screws to the shelf end panel.
2. Loosen top mounting screws on both end panels to reveal approximately 1/8" of screw thread.
3. With the flipper door assembly in the 'open' position (shown), position the rear slots of the flipper door assembly over the rear screws of the shelf end panel.
4. Slide the flipper door assembly back until the front slots drop over the front screws.
5. Seat flipper door assembly firmly over the four top shelf end panel screws then securely tighten all four flipper cover screws then all four shelf pan screws.

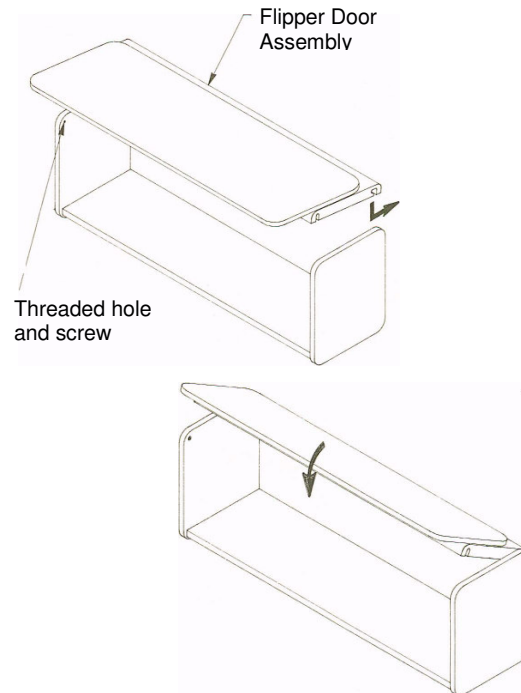

Tack Board & Marker Board Installation

1. Position and engage the hanger clips in panel joint or on wall hanger strip (*hanger clips are universal*) at desired height. See table below right for typical locations.
2. Position board with the mounting screws just above the hanger clips in the slots of the hanger clips as shown at right.
3. Press board against hanger clips and down to engage the mounting screws securely into the hanger clip notches.

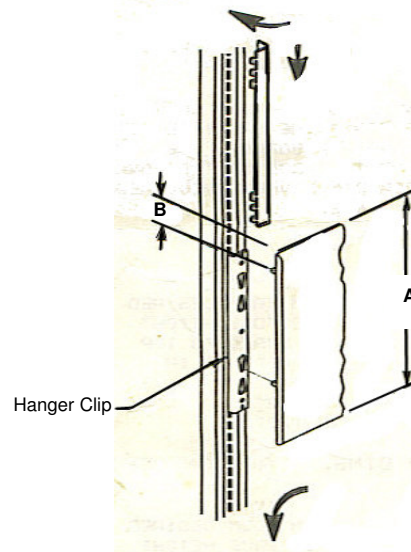

Marker Board Maintenance Notes:

- Use only dry erasable markers; never use permanent markers!
- If permanent marker is accidentally used, remove marks by writing over the marked area with dry erasable marker and immediately wiping it clean.
- Board can be wiped clean with a standard felt eraser. Use specifically-designed white board cleaner to aid cleaning and to minimize marker residue.
- If necessary, clean marker board with lacquer thinner to eliminate any residue left on the board from permanent markers or other non-approved writing instruments.
 - Note: Lacquer thinner is extremely flammable and harmful, or fatal, if swallowed. Vapor is harmful and is an eye and skin irritant. Avoid contact with skin or eyes; do not use near a heat source—fire or personal injury may result.
- Never use an abrasive cleanser on this surface which will cause the surface to deteriorate rapidly and deliver poor performance.

Dimension A Tack Board Height	Dimension B Mounting Screw Dimensions (from top)	Dimension from floor to top of hanger clip (approximate)
11 1/2"	1", 8"	40"
15 1/2"	4", 11"	41"

Task Lights

1. Install Task Light according to manufacturer's instructions, included with the light.
2. If using optional cord management clips, align task light cord inside reveal between panels. Plug light cord into outlet in panel base.
3. Use at least 3 cord clips per light to hold in place.

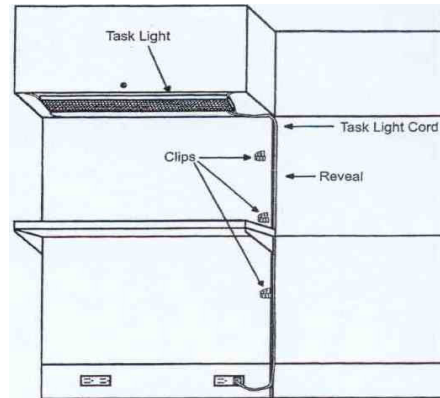

Storage Pedestals

1. Position storage component under work surface at desired location.
2. Remove pedestal drawers by fully extending drawer and slightly prying the drawer slide mechanism away from the drawer box using a slotted screw driver or mini Wonderbar/prybar from the bottom of the slide mechanism just behind the drawer front. Simultaneously lift the drawer box slightly away and repeat on the other side of the drawer.
3. Now hold both sides of the drawer box and pull toward you to disengage the tabs supporting the rear of the drawer box; pull drawer away entirely. Remove each drawer.
4. Level storage cabinet by adjusting each of the four glides until the top surface of the storage cabinet is flush with the work surface.
5. Use screws supplied with storage component to secure its four corners to the work surface through holes in the top frame.
6. Replace the drawers in the reverse sequence: align and insert tab/bayonet on side/rear of drawer box to slot on drawer slide; then attach in the same manner at front.
7. Test drawers for smooth operation; adjust if necessary.